



FEATURES

- Microprocessor based, with LCD display
- Used in conjunction with wide range of sensors/transmitters for a variety of parameters like
 - Temperature
 - Relative Humidity
 - Air differential pressure
 - Carbon dioxide
 - Enthalpy
- Digital/Analog set point
- Single/Multiple inputs
- Single/Multiple outputs
- ON-OFF, Modulating, 3-point operation

BENEFITS

- High accuracy
- Fast response
- Long life
- Good reproducibility
- Wide range for all the parameters
- Low hysteresis
- Low offset and drift
- Easy to operate

TECHNICAL DATA

Sensing element	Temp.	:	NTC Thermistor
	Humidity	:	High polymer type
	Voltage	:	0-10 V DC signal from transmitter
Sensing accuracy	Temp.	:	$\pm 0.5^{\circ}\text{C}$ or $\pm 1^{\circ}\text{C}$
	Humidity	:	$\pm 3\%$ rh or $\pm 5\%$ rh
	Voltage	:	Depends on transmitter
Display type*		:	2 line, alphanumeric, dotmatrix, STN, LCD with backlight
Display resolution*		:	0.1% of the maximum value
Digital output rating*		:	3A, 230 V AC
Terminals		:	Can accept max. 2.5 sq. mm cable
Permissible ambient temp.		:	-20° to 40°C

* wherever applicable

MODEL DESIGNATION

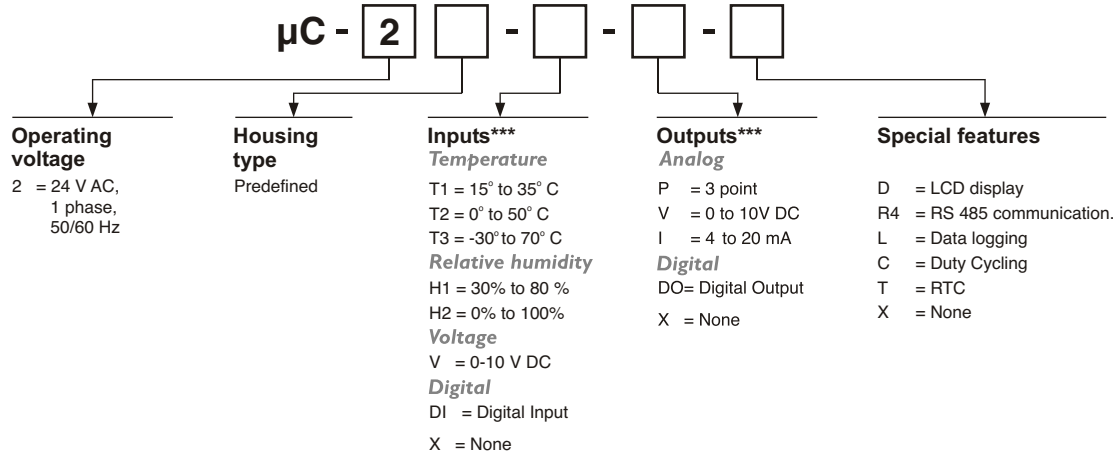

NOTES:

- *** In case of more than one input/output, the type of multiple input/output shall be specified in the same block, i.e., T1.H1, etc.
- *** In case of input from external sensor write E prior to that input, i.e., ET1.EH1, etc.